

CONVENTIONAL - Photoelectric Smoke Detector Model ECO1003 A

Overview

Features

- Low profile design
- Low current draw
- Automatic drift compensation
- Operates on 12 and 24VDC Systems
- Remote alarm test feature
- Easy Maintenance
- Range of detector bases available
- Remote LED Option
- Approved to EN54 – 7:2000 (Amendment 1)
- Approved to MED 96/98/EC (Amendment 2009/26/EC)
- Extended warranty



199m/01



G201060

0832-MED-1019
0832-MED-1020

Description

The ECO1003 A photoelectric smoke detector belongs to System Sensor's ECO1000 range of detectors. ECO1000 is a range of conventional detectors, which have been produced using the latest in manufacturing technology and supplied with an array of advanced features, making them 'better by design'.

The ECO1003 A photoelectric smoke detector uses a state of the art optical chamber combined with an application specific integrated circuit (ASIC) to provide quick and accurate detection of fires. A combination of the unique chamber design and other technically advanced features will significantly extend the service intervals before cleaning of the detector becomes necessary.

A laser-based hand held Remote Test Unit can be used in conjunction with the range of ECO1000 detectors for alarm test purposes. The unit transmits a coded message, preventing spurious alarms being generated by other laser-based devices. With a range of several metres, the hand held test unit provides a fast and simple way of remotely alarm testing the range of ECO1000 detectors and removes the need for any direct physical access to the detector by the user.

The ECO1003 A detector has an integral LED, which illuminates to provide a local alarm signal. This latches on, and remains illuminated until the detector is reset by a momentary power interruption. An optional remote LED annunciator may be used to repeat any alarm signal.

A variety of detector bases can be used with the ECO1003 A detector, providing application flexibility and compatibility with a wide range of Fire Alarm Control Panels. All bases are fitted with a shorting spring to permit circuit testing prior to fitting the detector and have a tamper resistant feature, which when activated prevents removal of the detector without the use of a tool.

All System Sensor products are covered by our extended 3-year warranty.

Architect/Engineer Specifications

ECO1003 Photoelectric Smoke Detector

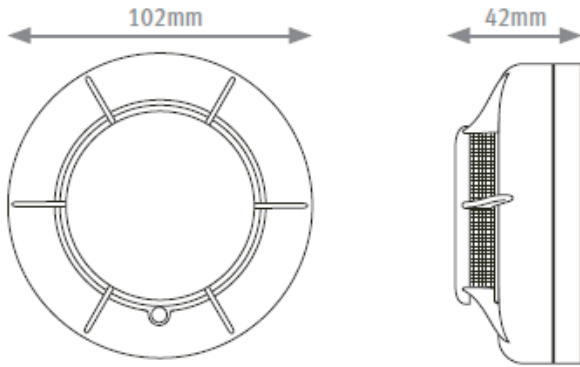

Electrical Specifications

Operating Voltage Range	8 to 30VDC (Nominal 12/24VDC)
Maximum Standby Current @ 25°C	60µA @ 24VDC
Maximum Permissible Alarm Current	80mA (current limited by control panel)

Environmental Specifications

Application Temperature Range (see note)	-30°C to +70°C
Humidity	0 to 95% Relative Humidity (non condensing)

Mechanical Information

Height	32.5mm (plus 9.5mm for standard base)
Diameter	102mm
Weight	75g (plus 45g for standard base)
Max Wire Gauge for Terminals	0.4mm ² to 2.0mm ²
Colour	Approximates to RAL9016
Material	ABS

Product Range

Bases	
ECO1000B Standard Base	ECO1000BSD Standard base with Shottky diode
ECO1000BR Resistor base 470 Ohm	ECO1000BRSD Resistor base 470 Ohm with Shottky diode
ECO1000DB Deep base	ECO1000DBSD Deep base with Shottky diode
ECO1000DBR Deep resistor base 470 Ohm	ECO1000DBRSD Deep resistor base 470 Ohm with Schottky diode
ECO1000BREL12L Relay base 12V Latching	ECO1000BREL12NL Relay base 12V Non –latching
ECO1000BREL24L Relay base 24V Latching	
Accessories	
ECO1000RTU Remote Test Unit	
Other Detectors	
ECO1002 A Photoelectric/Thermal Detector	ECO1004T A 78°C Fixed Temperature Thermal Detector
ECO1005 A Rate of Rise & 58°C Fixed Temperature	ECO1005T A 58°C Fixed Temperature Thermal Detector

Notes

Bases with other resistor values are available to suit the requirements of most Fire Alarm Control Panels.



WEEE/RoHS/REACH Assessment

ECO1003 A Product Evaluation Record

General information

Manufacturing Location	System Sensor Trieste Pittway tecnologica S.r.l. Via Caboto 19/3 34147 Trieste, Italy
Model Numbers	ECO1003 A
Product description	PHOTO DETECTOR ECO1000 SERIES
Product Life Cycle	Life span expectancy of >20 years (assuming that environmental conditions have been taken into consideration and the modules are regularly maintained)

Material Content

Name of Part	Material	RoHS	Hazardous	Recycling Instruction (WEEE is out of scope)
Dust cover	polystyrene	Yes	Non-hazardous	Re-used or recycled
Cover thermal/photo termal	ABS	Yes	Non-hazardous	Recycled by regrinding into granules and blending with virgin material or landfilled
Swirl chamber cover	ABS; PC+ABS - FR	Yes	Non-hazardous	Recycled or landfilled
Swirl chamber base	ABS+Stirene- Etilene-Butilene- Stirene (SEBS); ABSFR+ Stirene- Etilene-Butilene- Stirene (SEBS)	Yes	Non-hazardous	Not recyclable - landfilled
Light pipe	PMMA	Yes	Non-hazardous	Re-used or recycled
Cover	ABS	Yes	Non-hazardous	Re-used or recycled
Printed Circuit Board	CEM3 (Epoxy,Glass) SAC305 (Copper Coating, Solder)	Yes	Non-hazardous	Recycled or landfilled
Printed Circuit Board Components	Metals, Plastics, Ceramics, Tinned Stainless Steel, Tin Brass	Yes	Non-hazardous	Recycled or landfilled

Energy Consumption

ECO1003A	
Avg. Standby Power	1,08 mW (45 µA at 24 V) at 25°C one communication every 5 sec. With LED blink enabled
Max. Alarm Power (LED on)	1,92 W (80mA at 24VDC)

Environmental Permit

System Sensor Trieste Facility (address as above) approved to ISO 14001. These products do not require an environmental permit.

Packaging

Primary packaging	Single Box: Cardboard
Secondary packaging	Masterbox (5 Singlebox per M.box) and Shippingbox (28 M.box per S.box): cardboard, Tape (polypropylene)
Transportation packaging	Pallet (wooden platform), wrapping (polyethylene 04)

Additional Information

The purpose of this report is to provide information on the environmental aspects of the product, emphasis being on the material content and the energy consumption. Since there are not any emissions of harmful substances during the use of this product or in the manufacturing process of it, it is not necessary to specify these factors in this report. Also the transportation emissions are not included.

System Sensor (Technical Services)

System Sensor Europe
Unit C2
Foundry Lane, Horsham, West Sussex
RH13 5YZ, UK
Tel: +44 (0)1403 330240
Fax: +44 (0)1403 330695
Email: sse.technical@systemsensor.com
www.systemsensoreurope.com

System Sensor Europe (Customer Services)

Life Safety Distribution GmbH
Javastrasse 2, 8604 Hegnau
Switzerland
Tel: 0041 44 943 4400
Email: orders@systemsensor.com
www.systemsensoreurope.com