

FAAST LT-200 LOOP Model

Overview

Features

- High sensitivity LED Detection Chamber specially designed to cover Class C. Includes a high power output IR LED and high gain IR receiver amplifier
- Single & Dual channel versions with independent channels including fan, sensor and flow monitoring
- Supports System Sensor CLIP and Advanced protocol
- Provides pre-alarm functionality for graduated alarm thresholds
- Ultrasonic airflow sensing with expanded monitoring range
- A single device covers up to 2000m²
- Pipe-IQ™ software provides intuitive system layout and configuration all in one package
- Multiple event logging up to 2244 events
- User friendly air flow pendulum graph for verification of pipe network functionality
- Easily replaceable and reusable filter without affecting the rest of the device
- Protected electronics from air flow and accidental damage during installation or maintenance
- Designed for efficient wiring and installation: cable gland holes, easy access to the wiring area and no special tools required
- Easy access to parts requiring routine maintenance: filter(s) and sensor(s).
- IP65 enclosure



Description

The FAAST LT-200 Aspirating Smoke Detector is designed with the installer and end user in mind. It serves the wide variety of Class C applications where maintenance is difficult, where traditional smoke detection methods are inappropriate or prone to fail due to harsh environments or areas where aesthetics matter. It is also suitable for smaller mission critical applications where very early warning - Class A or B detection is required.

FAAST LT-200 combines proven aspirating detection technologies to deliver reliable smoke detection and efficient installation and maintenance. The device comprises innovative and intelligent internal design features designed to protect vulnerable components. These include a high sensitivity LED detection chamber (featuring a high power output IR LED and high gain IR receiver amplifier), along with ultrasonic flow sensors.

The device is fast to install and easy to commission thanks to PIPE IQ pipe design and configuration software which is included as standard.

FAAST LT-200 loop based devices are available as single channel and dual channel devices, offering flexibility for different detection strategies. A range of customisable settings are geared towards maximising device performance and meeting different application needs. Loop capability allows standard device integration, maintenance and support consistent with other Series 200 devices. The FAAST LT-200 loop device communicates as an output module with the fire system in System Sensor CLIP protocol (one address per channel) or in Advanced Protocol.

Architect/Engineer Specifications

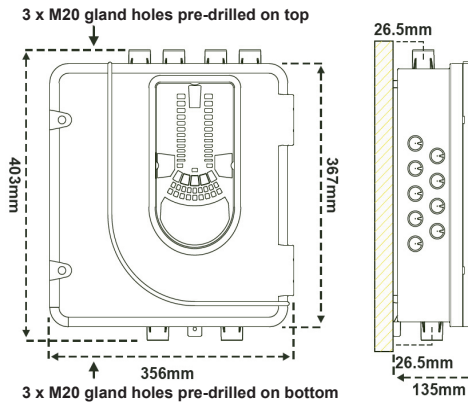

User Interface Display

The front panel will be different depending on which of the 3 Loop models is being installed.

The following display information is possible:

- Alarm level; Alarm, Pre-Alarm
- Particulate Levels; 1-5
- Fault Status
- Flow Level
- Test, Reset and Disable Buttons



Physical Specification

Height	403mm (including inlets and outlets)
Width	356mm
Depth	135mm
Cable Access	3 x M20 gland holes pre-drilled on top and bottom of the FAAST LT-200 unit
Wire Gauge	0.5mm ² to 2mm ² max
Maximum Single Pipe Length	100m
Maximum Total Branched Pipe Length	160m (per channel)
Maximum Air Inlet Holes	18 (per channel)
Outside Pipe Diameter	25mm or 27mm
Internal Pipe Diameter	15-21mm
Sensitivity Range	0.07 - 0.66 % obs/m (Alarm Level 1-5)
Relays	2 (1 Alarm, 1 Fault) x per Channel
Sounder outputs	1 per channel
Sound Performance	As low as 26db(A)
Event Log	2244 Events
Interfaces	Terminal blocks: power supply, relays, sounder outputs, external input; Loop Connection, USB port; Buttons (Test, Reset, Disable)
Power supply and relays connections	2mm ² max
USB	Standard USB cable for Type B USB connection
Shipping Weight- Including packaging material	6.5 kg (dual channel)
Flow monitoring and reporting	High and low according to EN54-20
Filtration	Replaceable filter
Fan control	10 programmable speeds

System Sensor Europe (Customer Services)

Life Safety Distribution GmbH
 Javastrasse 2, 8604 Hegnau
 Switzerland
 Tel: 0041 44 943 4400
 Email: orders@systemsensoreurope.com
 www.systemsensoreurope.com

System Sensor (Technical Support)

System Sensor Europe
 Unit C2
 Foundry Lane, Horsham, West Sussex
 RH13 5YZ, UK
 Tel: +44 (0)1403 330240
 Fax: +44 (0)1403 330695
 Email: sse.technical@systemsensoreurope.com
 www.systemsensoreurope.com

Electrical Specifications

Smoke Sensor(s)	High sensitivity LED Detection Chamber
External Supply Voltage	18.5-31.5 V
Remote Reset Time	2s
Power Reset	0.5s
Operating Current	
1 Channel Device	170mA @ 24 VDC (excluding sounders)
2 Channel Device	270mA @ 24 VDC (excluding sounders)
Max. Alarm Current	
1 Channel Device	360mA @ 24 VDC (excluding sounders)
2 Channel Device	570mA @ 24 VDC (excluding sounders)
Relay Contact Ratings	2.0 A @ 30 VDC, 0.5 A @ 30 VAC
Communication Loop Supply Voltage	15 – 29 VDC (Loop current ≤ 900mA)
Communication Loop Standby Current	@ 24V: 900 µA max. (poll once every 5s)

Environmental Specifications

Operating Temperature	-10°C to 55°C
Humidity Range	10% to 93% (non condensing)
IP Rating	65
Coverage Area	Up to 2,000m ² according to national design regulations

Ordering Information

Part No.	Description
FL2022EI-HS	Loop Based Dual Channel Detector
FL2012EI-HS	Loop Based Single Channel Dual Detector
FL2011EI-HS	Loop Based Single Channel Detector

Accessories

F-LT-EB	Earth Bar
FL-IF-6	FAAST LT-200 Integral Filter (6 filters)
Pipe and Fittings	Please see Aspiration Accessories Brochure

Listings and Approvals

VdS	
LPCB	
EN54-20 : (holes per channel)	Class A – 3 holes
	Class B – 6 holes
	Class C - 18 holes