

ANALOGUE - Photoelectric Smoke Sensor Model 2251EM

Overview

Features

- Compatible with existing System Sensor protocol
- Microprocessor precision control
- Automatic drift compensation.
- Enhanced signal processing for improved stability.
- Extended Temperature Range
- Twin LED indicators providing 360° visibility
- Rotary Decade Address Switches
- Stable communication with high noise immunity
- Tamper-Resistant (standard feature)
- Built in test switch
- Third party certified to EN54 – 7:2000 (Amendment 1)
(with multiple alarm thresholds)



199k/01



G200052



0832-CPD-0041

Description

The 2251EM photo-electronic sensor is a plug in smoke detector combining a photo-optical sensing chamber with addressable analogue communications and microprocessor control. The 2251EM features an improved design of sensing chamber, linked to sophisticated processing circuitry which incorporates smoothing filters to help eliminate transient environmental noise conditions, which can be the cause of unwanted alarms.

The detector's performance is further enhanced by the integration of special algorithms, which automatically compensate for contamination of the sensing chamber, hence providing a consistent level of sensitivity and increased immunity to unwanted alarm conditions. Should the maximum compensation range be exceeded the detector will generate a unique signal to the fire alarm control panel indicating a requirement for maintenance.

The sensor can be configured for differing application environments by selecting a suitable alarm threshold from within an approved range. (Refer to system supplier data).

The 2251EM has two integral LEDs which provide local visual indication of the sensor status. These LED's provide a dual function. In the event on an alarm, they are switched ON continuously, and can also be programmed to either blink when polled by the panel or remain off during normal conditions. In addition to its integral LEDs, the 2251EM can be connected to a Remote LED indicator (standard feature).

The individual loop address of each 2251EM can be easily set and read, using the rotary decade address switches located on the rear of each sensor. The use of decimal address codes significantly reduces the potential for incorrect address selection.

Each sensor base includes a tamper resistant option which, when activated, prevents the removal of the sensor from its base without the use of a tool. Full circuit functionality can be easily confirmed on site by use of the sensor test switch. Operation of this magnetic switch will generate an alarm response to the fire alarm control panel, making system testing both convenient and simple.

All System Sensor products are covered by our extended 3 year warranty.

Architect/Engineer Specifications

2251EM Photoelectric Smoke Sensor

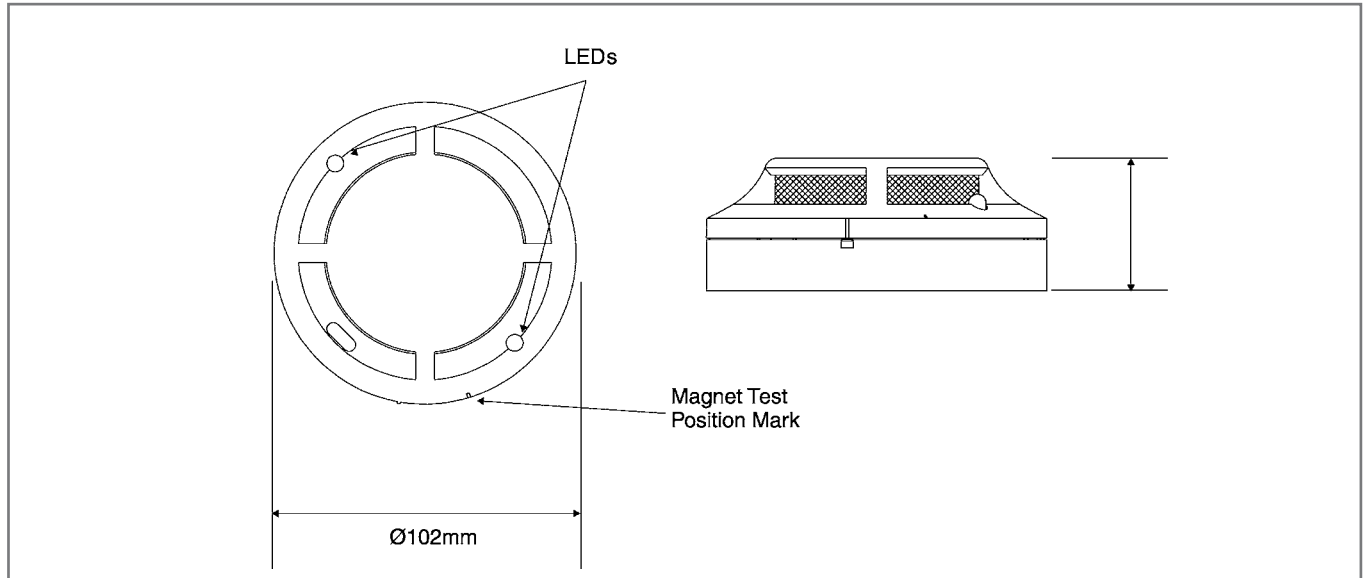

Electrical Specifications

Operating Voltage Range	15 to 32VDC
Maximum Standby Current	200µA at 24VDC (no communications)
Maximum Average Standby Current	300µA (One Communication each 5 seconds with LED blink enabled)
Maximum Alarm Current (LED On)	7mA at 24VDC

Environmental Specifications

Application Temperature Range	-20°C to 60°C
Short duration & storage	-30°C to 80°C
Humidity	10 to 93% Relative Humidity (non-condensing)

Mechanical Information

Height	43mm installed in B501 base
Diameter	102mm installed in B501 base
Weight	111g
Max Wire Gauge for Terminals	2.5mm ²
Colour	Pantone Warm Grey 1C
Material	Bayblend FR110

Product Range

Compatible Bases	B500 Series (B501, B501DG, B524RTE, B524IEFT-1)
Other Devices in range	Please refer to other Series 200 <i>plus</i> datasheets

System Sensor Europe (Technical Services)

Charles Avenue
Burgess Hill
RH15 9TQ
United Kingdom

Tel: +44 (0)1444 238820
Fax: +44 (0)1444 248123
Email: sse.technical@systemsensor.com
www.systemsensoreurope.com

Copyright © 2005 System Sensor. All rights reserved.
All technical data is correct at time of publication and is subject to change without notice. All trademarks acknowledged.
Installation information: in order to ensure full functionality, refer to the installation instructions as supplied.