

INTRINSICALLY SAFE - Rate of Rise Temperature Detector Model 5451EIS

Overview

Features

- Low profile design
- Low current draw
- Remote LED option
- Simple plug-in installation
- Compatible with standard B401 mounting base
- Built-in test switch
- Tamper-resistant
- Suitable for use in up to Zone 0 environments
- Approved for use with Zener safety barriers or galvanic isolators
- BASEEFA approval to EEx ia IIB T5
- Tested and approved to EN54 – 5:2000 (Amendment 1) Class A1R



118a/04

Baseefa03ATEX0155X

G296050

Description

Model 5451EIS is an intrinsically safe rate of rise detector with fixed temperature alarm. It uses state-of-the-art dual thermistor technology to provide maximum sensitivity. This detector is designed to afford open area protection and is for use in hazardous areas where potentially explosive atmospheres are likely to arise (confirm classification of equipment required with your responsible authority). Model 5451EIS detectors are designed to be used with compatible panels only.

Each detector has two LEDs to provide a local visual indication of detector status. Once the detector senses a fire, it latches in alarm and remains in this condition until it is reset by a momentary power interruption.

Model 5451EIS rate of rise detectors include a tamper feature that prevents removal from their mounting base (if enabled) without the use of a tool. In addition, these detectors can be easily tested by activating an internal reed switch with a test magnet.

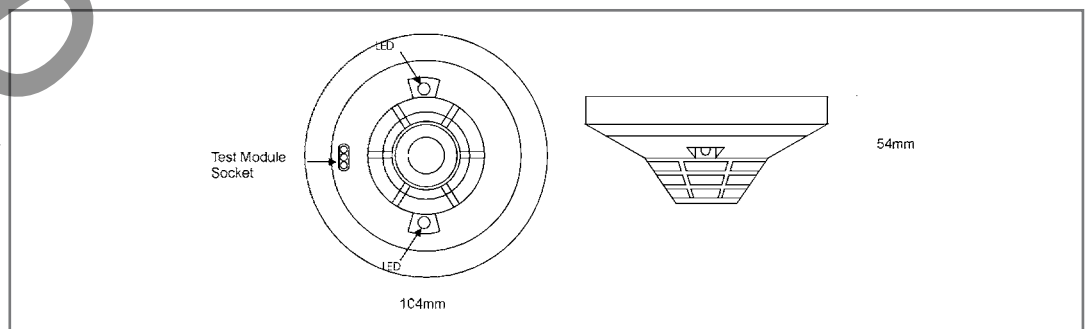

Architect/Engineer Specifications

5451EIS Intrinsically Safe Rate of Rise Temperature Detector

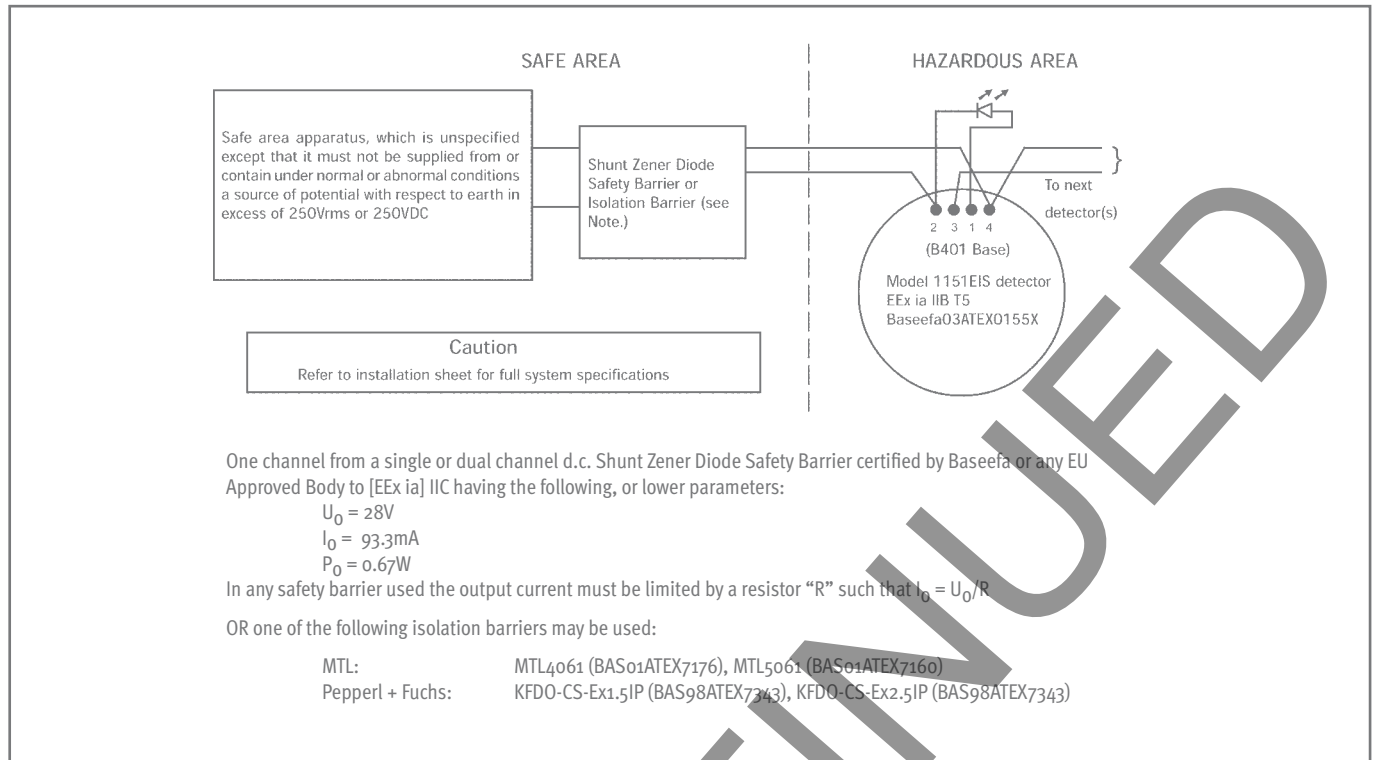

Electrical Specifications

Operating Voltage Range	15 to 32VDC Latching alarm reset by momentary power interruption
Standby Current (maximum)	100µA at 24VDC

Environmental Specifications

Application Temperature Range	-10°C to 55°C
Humidity	10% to 93% Relative Humidity (non-condensing)
IP Ratings	On application
Intrinsic Safety Rating	EEx II1G EEx ia IIB T5

Mechanical Information

Height	54mm
Diameter	104mm
Weight	80g (excluding base)
Max Wire Gauge for Terminals	2.5mm ²
Colour	Pantone Warm Grey 1C
Material	Bayblend FR110

Product Range

Compatible Bases	B401, B401DG
------------------	--------------

System Sensor Europe (Technical Services)

Charles Avenue
Burgess Hill
RH15 9TQ
United Kingdom
Tel: +44 (0)1444 238820
Fax: +44 (0)1444 248123
Email: sse.technical@systemsensoreurope.com
www.systemsensoreurope.com

Copyright © 2005 System Sensor. All rights reserved.
All technical data is correct at time of publication and is subject to change without notice. All trademarks acknowledged.
Installation information: in order to ensure full functionality, refer to the installation instructions as supplied.